

# ASSEMBLY AND OPERATING MANUAL

## LTW DRAG BOX

---



Manufacturer:	<b>LTW Tiefbauvertriebs GmbH</b> Holter Weg 11 D – 41836 Hückelhoven-Brachelen
Phone:	+49 (0) 24 62 / 2009 0
Fax:	+49 (0) 24 62 / 2009 15
e-mail:	info@LTW-Verbau.de
homepage:	<a href="http://www.LTW-Shoring.com">http:// www.LTW-Shoring.com</a>



### **General Instructions**

The following regulations and rules have to be followed in their valid version:

- Regulations of the BG-Fachausschuss Tiefbau (technical committee civil and underground engineering)
- DIN 4124 Baugruben und Gräben (excavation pits and trenches)
- DIN EN 13331 Teil 1 & 2 Grabenverbaugeräte (part 1 and 2 construction equipment)
- Regeln für Sicherheit und Gesundheit bei der Arbeit (rules for safety and health during work)
- Unfallverhütungsvorschriften / Arbeitsschutzvorschriften (regulations for the prevention of accidents and safety at work rules)

Please follow the instructions making use of our Boxes.

### ***Lifting & Transportation***

The shoring may only be attached at the corresponding eyes and openings and/or lifting accessories.

Lifting chains must be chosen to suit the weight being handled.

To prevent the accidental detachment of the load use only load hooks with safety catches.

The allowed tensile forces have to be kept in any cases.

Transportation has to be carried out next to soil and unneeded oscillations have to be avoided.

It is prohibited to stand within the pivoting range of the excavator or crane and beneath suspended loads.

When handling and removing the shoring, watch out for overhead contact lines (power cables).

A load operator must stand to the front of the excavator and be in eye contact with the machine operator.

### ***Measures to reduce hazards***

The safety of persons on site must be enhanced with the aid of signs, cones, warning tapes and/or safety staff specially deployed on site for this purpose.

Neighbouring traffic flow has to be made possible by means of safety staff if needed.

Personnel must wear protective clothing (helmet/safety shoes/gloves).

The risk of instability as a consequence of wind loads when setting up or using the shoring must be considered.

The shoring must be lowered onto level and firm ground. Where the ground is sloping or uneven, the shoring should be set up, if possible, at right angles to the slope.

### ***Maintenance & Repair***

Before use, all shoring components must be checked for their correct function.

Faulty or deformed parts must be replaced in any case.

Minor repairs can be carried out by the user, after consultation with LTW.

There is no warranty on incorrectly performed repairs and the use of non-original parts.

According to intenseness of use, the components should be painted with anticorrosion paint every two years.

System view

Flange 500

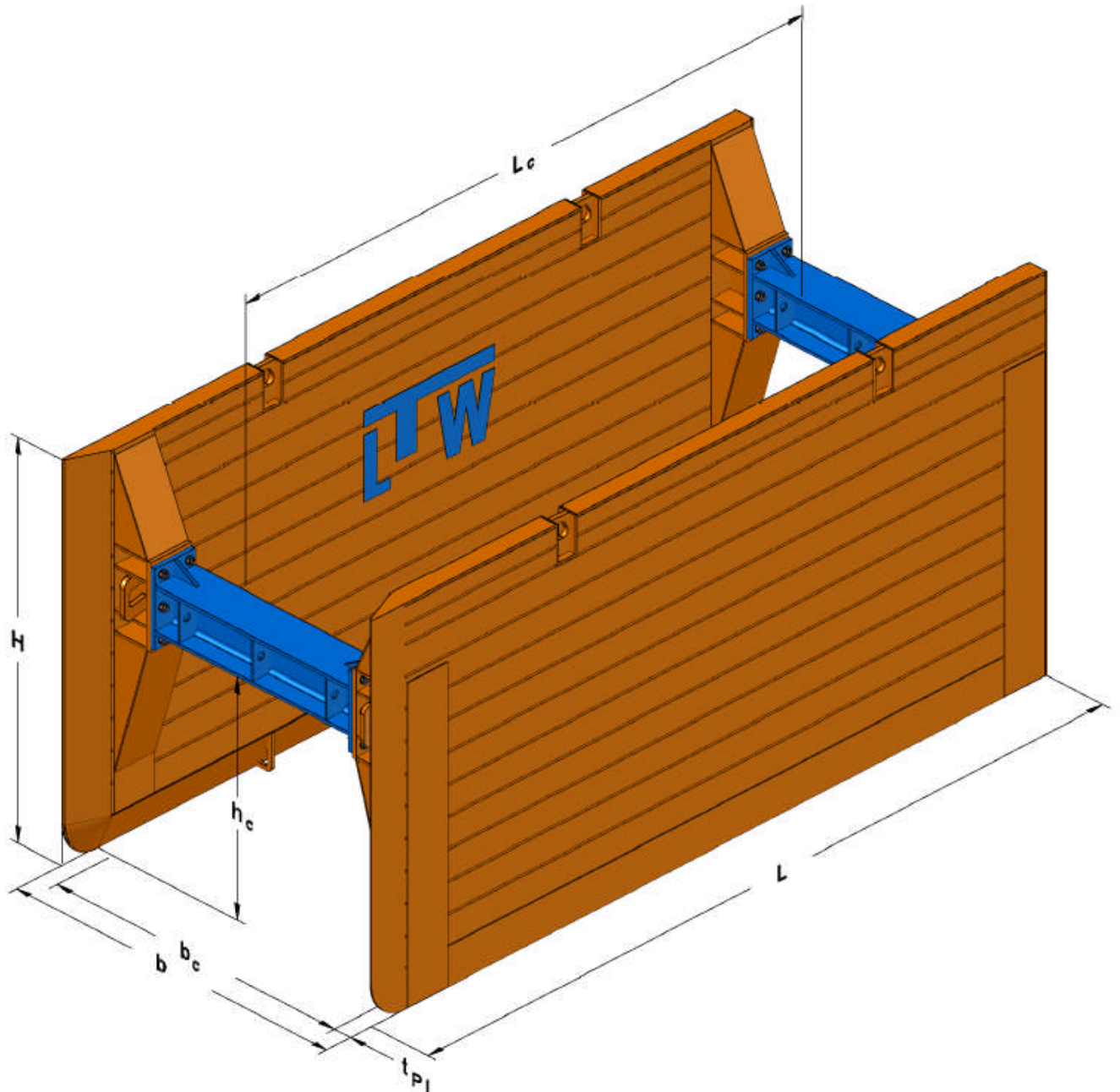

**B** DRAG BOX  
**H** plate height

$b$  shoring width  
 $b_c$  inner working width  
 $t_{PI}$  plate thickness

$h_c$  pipe culvert height  
 $L$  plate length  
 $L_c$  pipe culvert length



**Technical Characteristics: DRAG BOX - Flange 500**

**plate height 2,50m**

plate length L [ m ]	plate height H [ m ]	plate thickness t <sub>PI</sub> [ mm ]	pipe culvert length L <sub>C</sub> [ m ]	pipe culvert height h <sub>C</sub> [ m ]	limit state design load e <sub>d</sub> [ kN / m <sup>2</sup> ]	plate weight G <sub>PL</sub> [ kg ]	box weight G <sub>E</sub> [ kg ]
4,24	2,50	120	3,36	1,60	70,2	1655	3320
4,74	2,50	120	3,86	1,60	59,3	1795	3590
5,24	2,50	120	4,36	1,60	47,1	1930	3870
5,74	2,50	120	4,86	1,60	46,9	2315	4630
6,24	2,50	120	5,36	1,60	38,9	2475	4950

**plate height 3,00m**

plate length L [ m ]	plate height H [ m ]	plate thickness t <sub>PI</sub> [ mm ]	pipe culvert length L <sub>C</sub> [ m ]	pipe culvert height h <sub>C</sub> [ m ]	limit state design load e <sub>d</sub> [ kN / m <sup>2</sup> ]	plate weight G <sub>PL</sub> [ kg ]	box weight G <sub>E</sub> [ kg ]
4,24	3,00	120	3,36	1,80	55,9	1965	3940
4,74	3,00	120	3,83	1,80	50,4	2130	4270
5,24	3,00	120	4,36	1,80	45,9	2295	4600
5,74	3,00	120	4,86	1,80	42,1	2755	5520
6,24	3,00	120	5,36	1,80	38,9	2945	5900

# ASSEMBLY AND OPERATING MANUAL

## LTW DRAG BOX



### Tensile Forces

pulling eyes	$R_d = 344 \text{ kN}$
lifting eyes at the plate head	$R_d = 344 \text{ kN}$
bottom eyes	$R_d = 109 \text{ kN}$

### Distance piece (Extension) - Flange 500

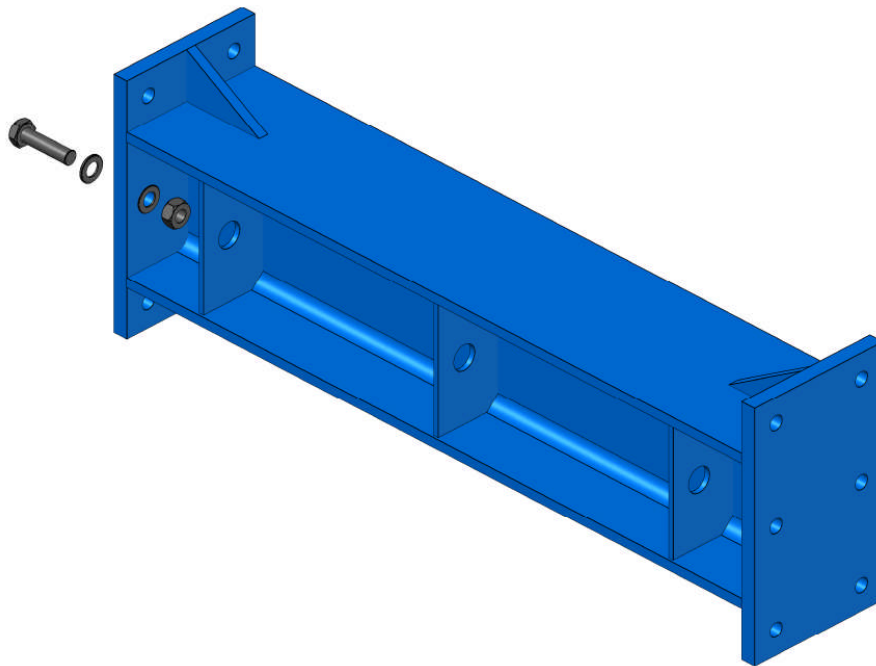

length of distance piece [ m ]	working width $b_c$ [ m ]	shoring width $b$ [ m ]	weight $G$ [ kg ]
-	0,58	0,82	-
0,50	1,08	1,32	138
1,00	1,58	1,82	209
1,50	2,08	2,32	269
2,00	2,58	2,82	329

### Screw Set:

dimension	material	standard	Qty.
M27 * 100	10.9	DIN 6914 zinc coated	6
M27	10	DIN 6915 zinc coated	6
Ø28	St	DIN 6916 zinc coated	12

System view

Flange 700

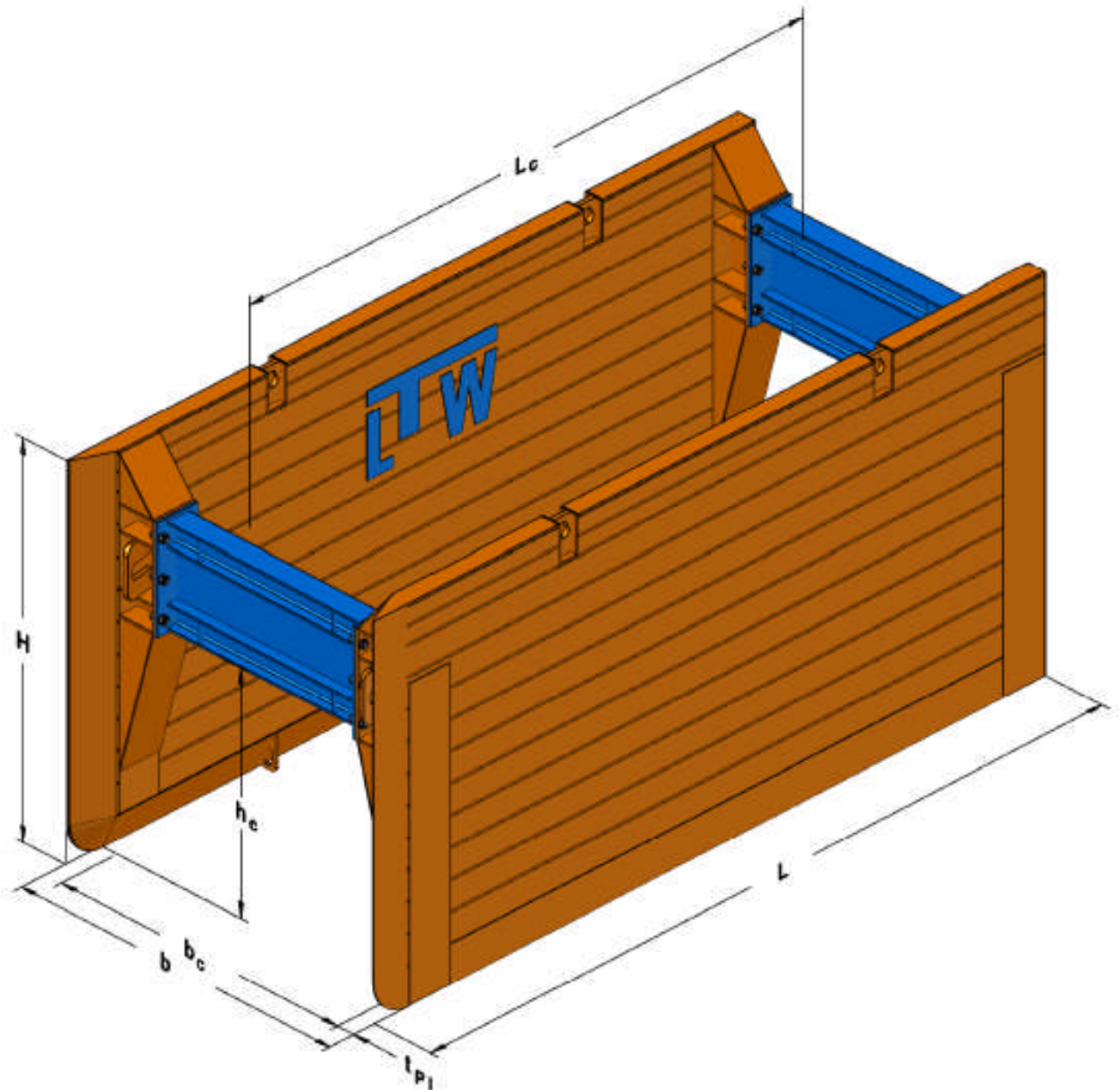

**B** DRAG BOX  
**H** plate height

**b** shoring width  
**b<sub>c</sub>** inner working width  
**t<sub>p1</sub>** plate thickness

**h<sub>c</sub>** pipe culvert height  
**L** plate length  
**L<sub>c</sub>** pipe culvert length

# ASSEMBLY AND OPERATING MANUAL

## LTW DRAG BOX



### Technical Characteristics: DRAG BOX - Flange 700

#### plate height 2,50m

plate length L [ m ]	plate height H [ m ]	plate thickness t <sub>PI</sub> [ mm ]	pipe culvert length L <sub>c</sub> [ m ]	pipe culvert height h <sub>c</sub> [ m ]	limit state design load e <sub>d</sub> [ kN / m <sup>2</sup> ]	plate weight G <sub>PL</sub> [ kg ]	box weight G <sub>E</sub> [ kg ]
4,24	2,50	120	3,36	1,60	66,5	1655	3320
4,74	2,50	120	3,86	1,60	59,3	1790	3590
5,24	2,50	120	4,36	1,60	47,1	1930	3860
5,74	2,50	120	4,86	1,60	46,9	2310	4630
6,24	2,50	120	5,36	1,60	38,9	2470	4950

#### plate height 3,00m

plate length L [ m ]	plate height H [ m ]	plate thickness t <sub>PI</sub> [ mm ]	pipe culvert length L <sub>c</sub> [ m ]	pipe culvert height h <sub>c</sub> [ m ]	limit state design load e <sub>d</sub> [ kN / m <sup>2</sup> ]	plate weight G <sub>PL</sub> [ kg ]	box weight G <sub>E</sub> [ kg ]
4,24	3,00	120	3,36	1,80	55,9	1965	3930
4,74	3,00	120	3,86	1,80	50,4	2125	4260
5,24	3,00	120	4,36	1,80	45,8	2290	4590
5,74	3,00	120	4,86	1,80	42,1	2750	5510
6,24	3,00	120	5,36	1,80	38,9	2940	5890

#### plate height 3,50m

plate length L [ m ]	plate height H [ m ]	plate thickness t <sub>PI</sub> [ mm ]	pipe culvert length L <sub>c</sub> [ m ]	pipe culvert height h <sub>c</sub> [ m ]	limit state design load e <sub>d</sub> [ kN / m <sup>2</sup> ]	plate weight G <sub>PL</sub> [ kg ]	box weight G <sub>E</sub> [ kg ]
4,24	3,50	120	3,36	1,80	55,9	2205	4420
4,74	3,50	120	3,86	1,80	50,4	2390	4790
5,24	3,50	120	4,36	1,80	45,8	2575	5160
5,74	3,50	120	4,86	1,80	42,1	3130	6260
6,24	3,50	120	5,36	1,80	38,9	3345	6700

# ASSEMBLY AND OPERATING MANUAL

## LTW DRAG BOX



### Tensile Forces

pulling eyes	$R_d = 344 \text{ kN}$
lifting eyes at the plate head	$R_d = 344 \text{ kN}$
bottom eyes	$R_d = 109 \text{ kN}$

### Distance piece (Extension) - Flange 700

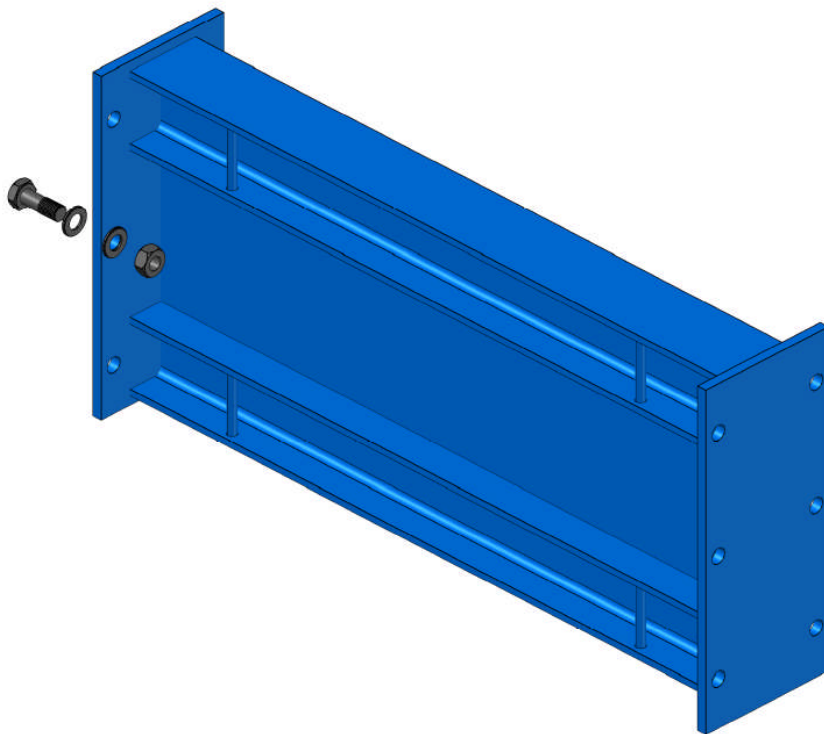

length of distance piece [ m ]	working width $b_c$ [ m ]	shoring width $b$ [ m ]	weight $G$ [ kg ]
-	0,56	0,80	-
0,50	1,06	1,30	123
1,00	1,56	1,80	177
1,50	2,06	2,30	233
2,00	2,56	2,80	287

### Screw Set:

dimension	material	standard	Qty.
$M 30 * 85$	10.9	DIN 6914 zinc coated	6
$M 30$	10	DIN 6915 zinc coated	6
$\varnothing 31$	St	DIN 6916 zinc coated	12



### Assembly Instruction

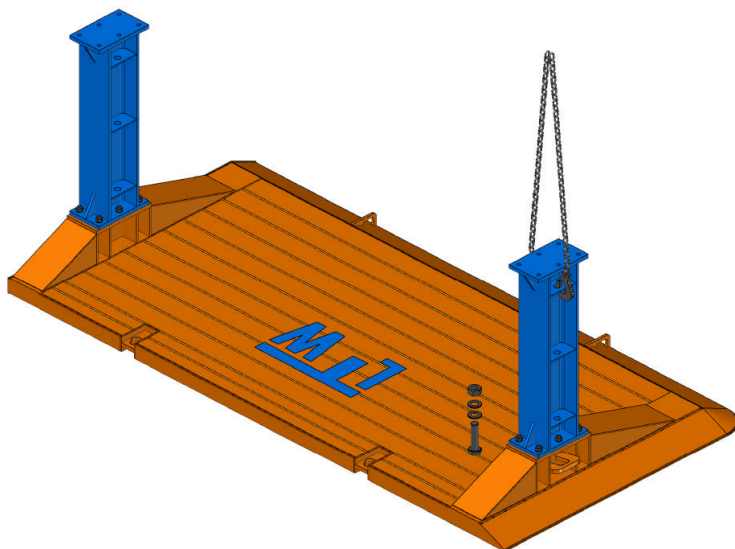

Place the Plate on the attachment points facing with the flange assembly upwards.

Depending on the required trench width Distance pieces (Extensions) have to be used. Lift the Distance piece by connecting the rope to the corresponding lifting/transportation point. Adjust the adapter (flange) to the plate and use two washers for the screw and nut to tighten it.

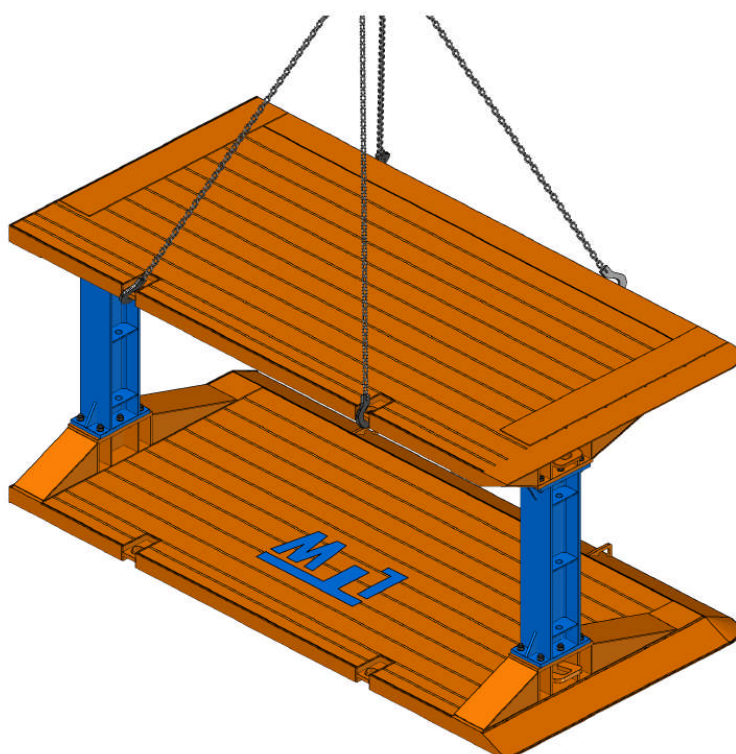

Use the lifting/transportation points at the top and the cutting edge to lift the second plate above the first plate. Tighten the screws as described above.

### Installation Instruction

The Drag Boxes have been designed only for open country applications to be used in temporary steady soil. A small area (in between the plates) is protected for pipe laying application. The face sides (front edges) are unprotected and need to be sloped. The excavation follows ahead and the Excavator pulls the Drag Box in the next position. Backfilling and compaction will be effected behind the Box, Pipe laying only in the secured area within the plates.

**The System is not suitable for being used inner city with lots of service lines and can only be installed in the place in position method.**

### ***Place in position method***

The DRAG BOX is placed into the totally pre-excavated trench.

The place in position method is only allowed if the following conditions are given:

- temporary steady soil; no local groundwater
- outside of the sphere of influence of buildings and structures
- outside of the sphere of influence of circulation spaces and endangered lines
- Settlements can be accepted

The ground is considered as temporary firm, if no mayor collapses is noted in the period from the start of the excavation until the insertion of the shoring.

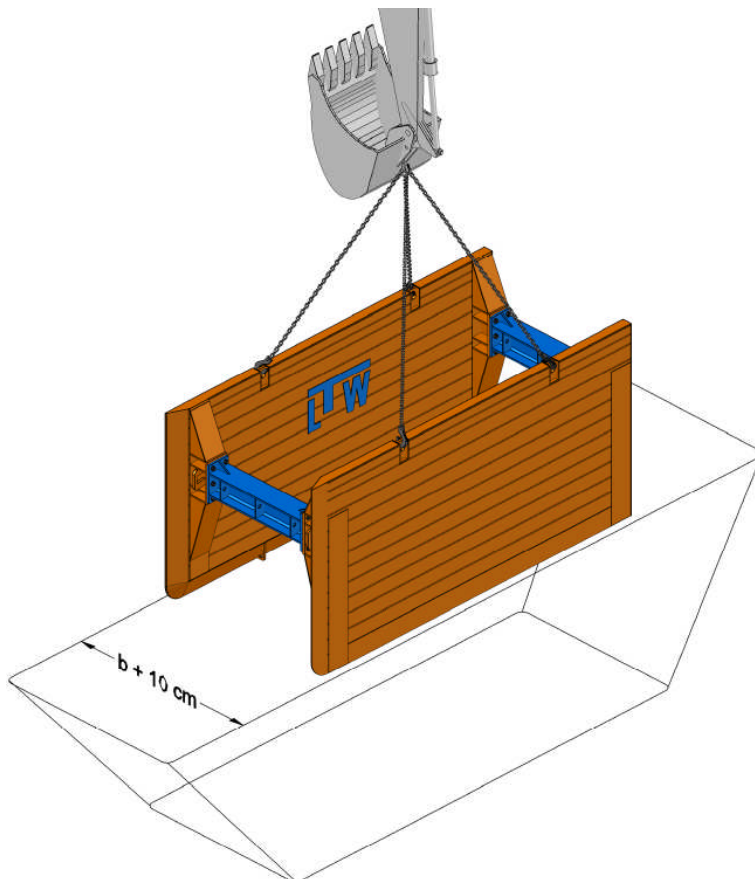

The pre-dug trench should be ~10cm wider than required trench width. The face sides are unprotected and need to be sloped depending on soil conditions.

### Principle of Operation

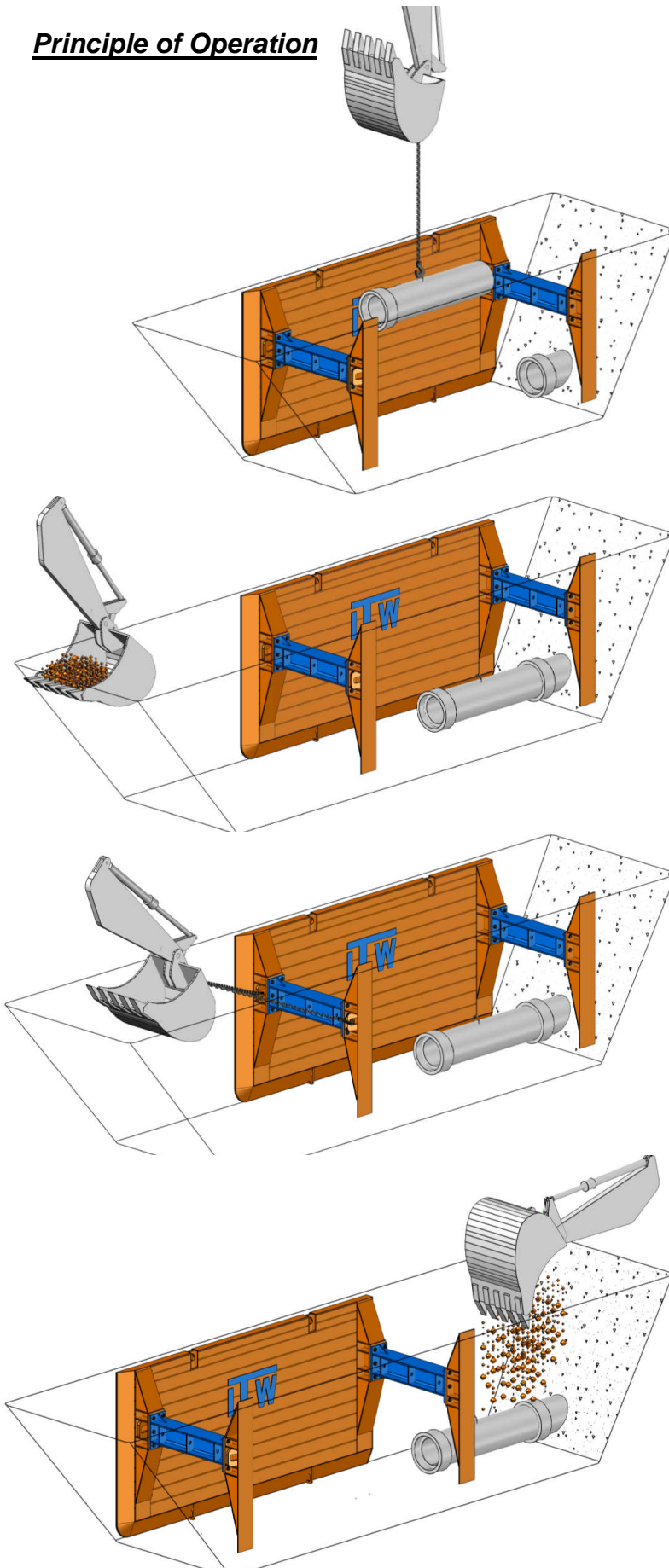

The Drag Box act as shield in the event of trench wall instability. Only the Pipe laying will be effected in between the Shield.

**Do not enter the unprotected area outside the Drag Box.**

Before the Box will be pulled forward into next section, you have to leave the excavation. It is prohibited to stay in the danger zone.

For pulling the Box forward into the ahead excavation, the chain has to be attached to the drag-eyes located in the front of the Box.

**Do not pull the Box forward on the front strut !**

Backfilling and compacting must be effected behind the Box. Only the Pipe Laying will be effected in between the Shield.

### Re - Installation

After completion of the Pipe laying the re-installation of the shoring can be effected.

For lifting up the Drag Box out of the trench, the corresponding lifting eyes in the plate head should be used.

**Do not try to lift up the Box on the struts!**

It is prohibited to stand within the pivoting range of the excavator or crane and beneath suspended loads.

In order to avoid an overstraining of the shoring plates, do not lift one-sided.